

PART NUMBER WITH S SUFFIX HAS CB9194 BLANKET INSTALLATION SPEAR ATTACHED TO PUNCTURE BLANKET. REPLACE WITH CB9174 OR CB9208 RETAINER TO HOLD BLANKET IN POSITION.

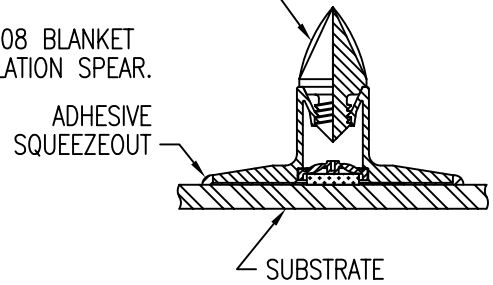
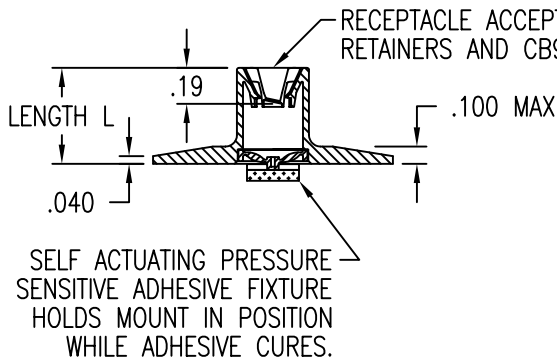

SELF ACTUATING PRESSURE SENSITIVE ADHESIVE FIXTURE HOLDS MOUNT IN POSITION WHILE ADHESIVE CURES.

MATERIAL DATA

| CODE | MATERIAL | FINISH |
|------|-------------------------------------|----------------|
| V | POLYETHERIMIDE THERMOPLASTIC, 350°F | ABRASIVE CLEAN |

LENGTH L DATA

| CODE | L |
|------|------|
| 8 | .50 |
| 28 | 1.75 |

EXAMPLE PART NUMBER

CB9210 V 3-8 S 750

OPTIONAL TRIMMED BASE - .750
 OPTIONAL CB9194 BLANKET INSTALLATION SPEAR ATTACHED
 LENGTH L IN 16THS - .50
 THREAD SIZE - .1900-32 BUTTRESS DOUBLE LEAD
 MATERIAL - POLYETHERIMIDE
 BASIC PART NUMBER

UNLESS OTHERWISE SPECIFIED, ALL DIMENSIONS ARE IN INCHES AND TOLERANCES ARE AS SHOWN BELOW. DIMENSIONAL TOLERANCES AND SYMBOLS PER ANSI Y14.5M-1982.

PROPRIETARY PARTS SHOWN IN THIS DRAWING ARE THE SUBJECT OF ISSUED UNITED STATES AND FOREIGN PATENTS AND PATENTS PENDING. UNAUTHORIZED REPRODUCTION AND/OR DISTRIBUTION OF THIS DRAWING IS SPECIFICALLY PROHIBITED.

GLICK BOND

CARSON CITY
NEVADA 89706

| | | APPROVALS | DATE |
|--------|-------|--------------|---------|
| ANGLES | ±1° | DRAWN DAC | 26MAR02 |
| .XX | ±.03 | CHECKED DAC | 26MAR02 |
| .XXX | ±.010 | RELEASED ABC | 26MAR02 |
| .XXXX | ±.001 | REVISED DAC | 26MAR02 |

| TITLE | | | |
|--------------------------------------|-------------|----------|--------------|
| RECEPTACLE, INSULATION BLANKET MOUNT | | | |
| SIZE | CAGE CODE | DWG. NO. | REV. |
| A | 66530 | CB9210 | 3 |
| SCALE | 1/1 26MAR02 | | SHEET 1 OF 1 |