

- NOTES
1. ALL DIMENSIONS BEFORE PAINT OR PLATING
  2. FOR L MAX DIMENSION, LENGTH IS  $L \pm .010$
  3. FIXTURED (CODE "E" OR NONE) SLEEVES WITH CODE "-" SURFACE FINISH SHALL BE SUPPLIED WITH POWDER BLAST FINISH
  4. .001 MAX BURR PERMISSIBLE ON INTERIOR AT END OF PART
  5. GAGE FIXTURE POSITIONS SLEEVE TO PROVIDE FLUSH MOUNTING OF 100° FULL FLUSH HEAD FASTENER (NAS1580) PER NAS9800 TYPE B.
  6. FOR L LESS THAN L MIN, GAGE FIXTURE NOT AVAILABLE; DO, DI, AND R ARE REFERENCE DIMENSIONS

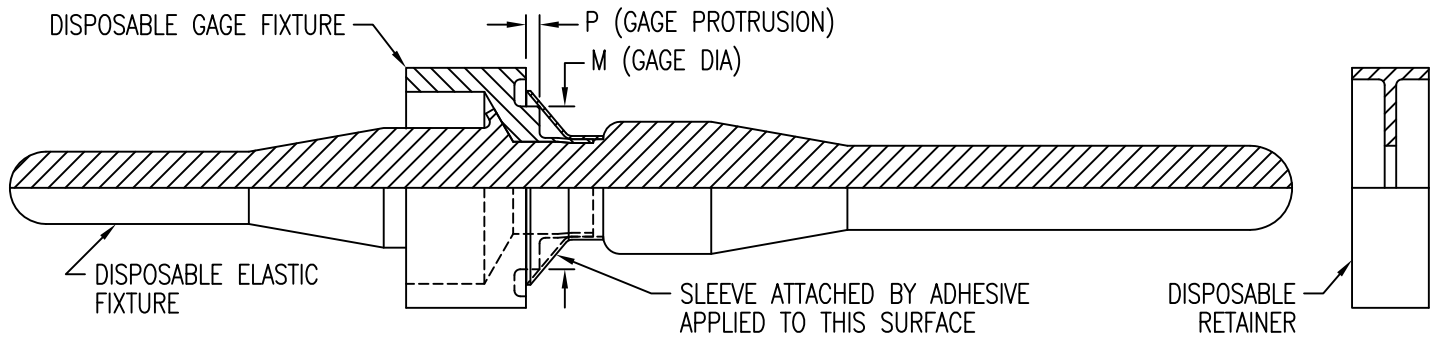

DIMENSION DATA

CODE	SIZE	A DIA	DI DIA	DO DIA	L MIN	L MAX	(HF)	(HS)	(M)	(P)
55	.1640	.328	.1670-.1685	.1840-.1850	.100	.750	.070	.074	.2670	.0280
06	.1900	.380	.1930-.1945	.2095-.2105	.125	1.000	.080	.084	.3146	.0301
08	.2500	.505	.2530-.2545	.2696-.2706	.150	1.000	.108	.112	.4244	.0354
10	.3125	.631	.3155-.3170	.3321-.3331	.175	1.000	.135	.139	.5388	.0407
12	.3750	.758	.3780-.3795	.3946-.3956	.200	1.000	.162	.166	.6531	.0463

MATERIAL AND FINISH DATA

CODE	MATERIAL	SPEC.	CONDITION	PASSIVATE
C	A-286 CRES	AMS 5525	AS FORMED	AMS 2700
D	A-286 CRES	AMS 5525	ANNEALED	AMS 2700

FIXTURE CODE

CODE	FIXTURE COMPONENTS
NONE	GAGE, ELASTIC, & RETAINER
E	ELASTIC & RETAINER
N	NO FIXTURE

SURFACE FINISH

CODE	TREATMENT
-	NONE
B	POWDER BLAST
C	CAD PLATE
P	EPOXY PRIMER
AC	ALUMINUM COAT

EXAMPLE PART NUMBER

CB5906 C 08 B 200

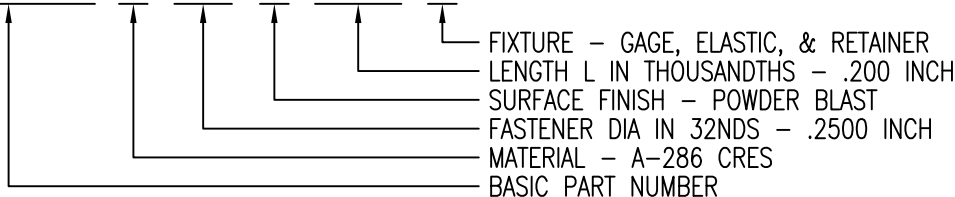

FIXTURE - GAGE, ELASTIC, & RETAINER  
 LENGTH L IN THOUSANDTHS - .200 INCH  
 SURFACE FINISH - POWDER BLAST  
 FASTENER DIA IN 32NDS - .2500 INCH  
 MATERIAL - A-286 CRES  
 BASIC PART NUMBER

UNLESS OTHERWISE SPECIFIED, ALL DIMENSIONS ARE IN INCHES AND TOLERANCES ARE AS SHOWN BELOW. DIMENSIONAL TOLERANCES AND SYMBOLS PER ANSI Y14.5M-1982.

PROPRIETARY PARTS SHOWN IN THIS DRAWING ARE THE SUBJECT OF ISSUED UNITED STATES AND FOREIGN PATENTS AND PATENTS PENDING. UNAUTHORIZED REPRODUCTION AND/OR DISTRIBUTION OF THIS DRAWING IS SPECIFICALLY PROHIBITED.



CARSON CITY  
NEVADA 89706

PANDOR

APPROVALS	DATE
DRAWN <i>DAC</i>	20MAY12
CHECKED <i>DAC</i>	20MAY12
RELEASED <i>KGH</i>	20MAY12
REVISED <i>DAC</i>	20MAY12

TITLE			
SLEEVE, BOLT CLEARANCE, 100° TENSION HEAD, ADHESIVE BONDED			
SIZE	CAGE CODE	DWG. NO.	REV.
A	66530	CB5906	4
SCALE	4/1	20MAY12	SHEET 1 OF 1